

4

3

2

1

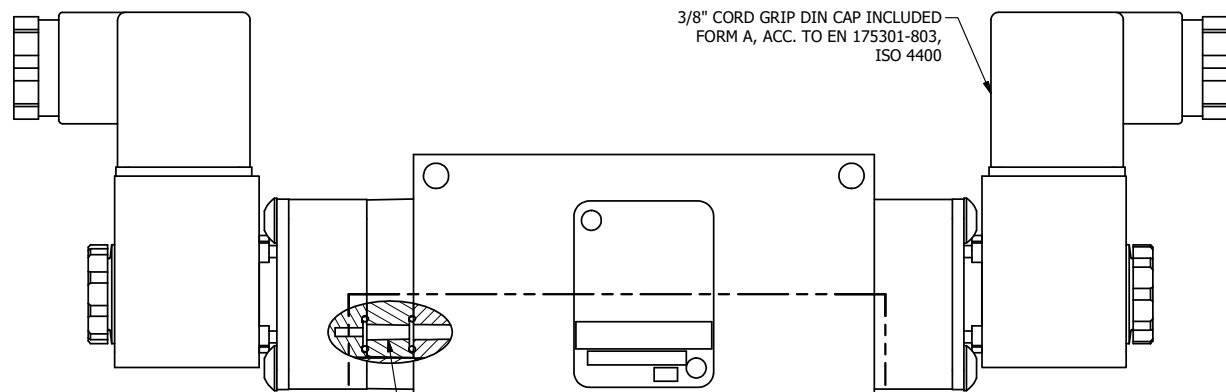

3/8" CORD GRIP DIN CAP INCLUDED
FORM A, ACC. TO EN 175301-803,
ISO 4400

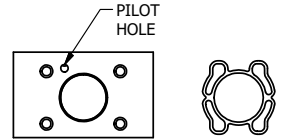

ALIGN PILOT AND SLOT IN ADAPTOR
WITH GASKET IN BETWEEN, BOTH SIDES.
FOR EXTERNAL PILOT OPERATION - ROTATE ADAPTOR
180 DEGREES. REMOVE 1/8" NPTF PLUG AND
SUPPLY 50-150 PSI TO 1/8" NPTF PILOT PORT IN ADAPTOR.

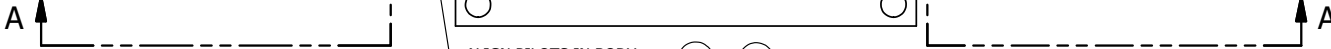

ALIGN PILOTS IN BODY,
END CAP AND SOLENOID

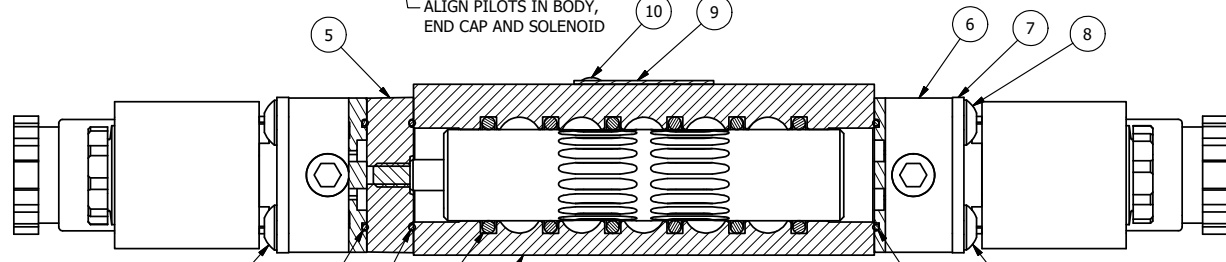

SIDE 'B'

SIDE 'A'

SECTION A-A
SCALE 1 : 1
VIEW FROM 3 PORT SIDE

NOTES:
1) ALWAYS GIVE VALVE MODEL AND PART NUMBER WHEN ORDERING PARTS.

FLG	QTY	PART NO	DESCRIPTION
10	2	V-212	SCREW, #2 X 3/16 DRIVE, TYPE U, OVAL HEAD, STAINLESS STEEL
9	1	AN-114	NAMEPLATE, BLANK, FOR VALVES WITH SPRINGS OR DETENTS
8	4	V-584	SCREW, 10-24 X 1, BUTTON HEAD SOCKET CAP WITH MICROSPHERE APPLIED TO THREADS.
7	2	SEC3-7	PLATE, RE-INFORCEMENT, SOLENOID, STAMPED, 304 STAINLESS
6	2	V-564	SYSTEM 8 INTRINSICALLY SAFE SOLENOID OPERATOR.
5	1	AY-EM3D	ASSY - SPR CTR, REGEN CTR SPL, END MOUNT SOLENOID, 1/4" & 3/8" VALVES
4	4	V-601	SCREW, 10-24 X 1-1/2, BUTTON HEAD SOCKET CAP WITH MICROSPHERE ADHESIVE
3	3	EMG3	GASKET - END MOUNT SOLENOID, BUNA-N, 1/4" & 3/8" VALVES
2	6	V-39	O-RING, VITON, STD BODY, 1/4" & 3/8" VALVES
1	1	B2-1E	BODY - SOLID, BUTTON BLEEDER, ANODIZED, 1/4" SIDE PORT VALVE

LIMITS ON DIMENSIONS
UNLESS OTHERWISE SPECIFIED
2-PL DECIMAL ± .01
3-PL DECIMAL ± .005
FRACTIONAL ± 1/64
ANGULAR ± 1/2°



DRAWN: RMckenna DATE: 10/20/2015 CHECKED: KWaite DATE: 10/20/2015
SCALE: 1 : 1 SHEET: 1 OF 1 RELEASED: HWomack DATE: 10/20/2015

TITLE: 1/4" SIDE PORT, DBL SOL, 3 POS, SPR CTR, SOL SHFT, REGEN CTR SPL, INTRINSICALLY SAFE, 24VDC
PART NO.: ESY2DA 24VDC
REV.: A

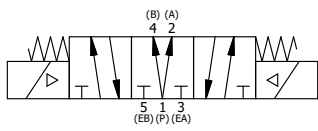

A	NO.	DATE	REVISION
6/1/2018	ECG3 GASKET TO EMG3, CHNGD END CAP GEOM.		

4

3

2



THE INFORMATION CONTAINED WITHIN THIS DOCUMENT IS PROPRIETARY TO AAA PRODUCTS AND MAY NOT BE DISCLOSED WITHOUT PRIOR WRITTEN CONSENT

P:\Engineering\Product Valve Assembly\Standard 24VDC.dwg